

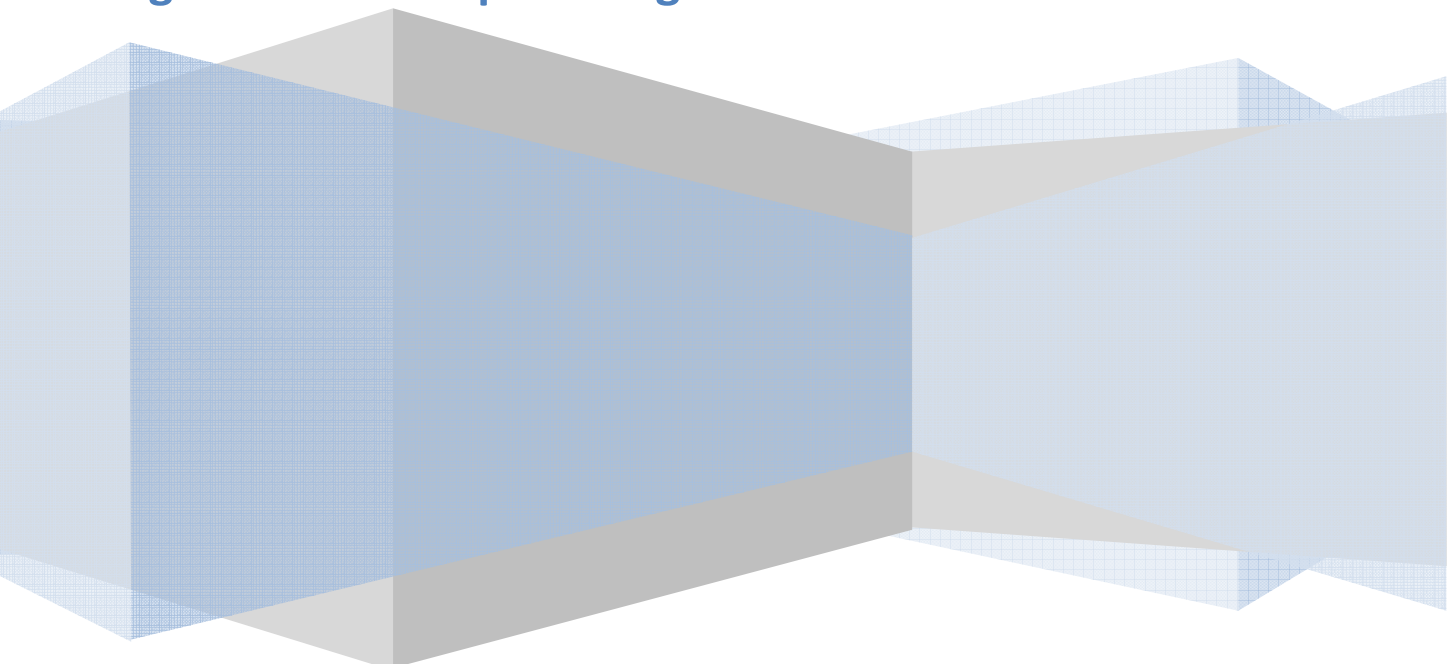

# MUSKAN FORGE INDUSTRIES



## Flanges & P.T.F.E Pipe Fitting Products





# MUSKAN FORGE INDUSTRIES

All Types of simlless Pipes Manufacturer of Flanges & P.T.F.E Pipe Fitting & Butt Weld Pipe Fitting of Stainless Steel & Carbon Steel

MFG UNIT: 16/A, Panchal Udhyog Nagar, Opp Old Syndicate bank, Ghoddev Phatak Road, Bhayander (E) Thane - 401105

## About US

We **Muskan Forge Industries** are manufacturing and supplying a wide range of ferrous and non ferrous metal products. Catering to various industrial projects in India, we have earned the reputation as a dependable supplier among our vast international client base.

This position is earned due to our ongoing mission to offer consistency in quality for both our products and services. We offer a complete line of standard as well as customized metal products to our clients. Our comprehensive range of products includes carbon steel, stainless steel, ferrous & non ferrous metal products in shape of pipe, plates and pipe fittings.

Superior quality products and complete customer satisfaction is our forte. For ensuing these factors in our business process, we come with requisite facilities in terms of infrastructure and human resources. Headquartered in Mumbai, it enables us to offer precision products in stipulated time-frame.

We are a reputed firm, which is successfully fulfilling the requirements of a large number of individuals and clients by its offered products. All our products are developed with the use of supreme grade in sync with international norms. For meeting the numerous needs of the market, our firm offers products in different sizes, grades and specifications. The products we offer find their extensive use in the various industrial areas.

In just more than three decades of existence **Muskan Forge Industries** has earned an outstanding reputation as a leading edge manufacturer and supplier of original quality and cost efficient pipe fittings. Over the years we have been able to distinguish ourselves as a leading producer of quality pipe fittings, simply by consistently defining and refining excellence - excellence in products, excellence in process & excellence in customer care.

We have gained significant experience and exposure in dealing with such high profile clients in addition to our relentless efforts to achieve excellence in our service through in house strength of technically qualified personnel, well documented quality control procedures etc.

Proprietor – **Abdul Aziz Shaikh**

---

Regd Add: - B-1/409, Jyoti Park, Opp. Indralok Complex Phase-I, New Golden Nest Road, Bhayander (East) Thane-401105

Email: - [muskanforgeind@yahoo.in](mailto:muskanforgeind@yahoo.in)

Tell: - +9122 28165151



# MUSKAN FORGE INDUSTRIES

All Types of seamless Pipes Manufacturer of Flanges & P.T.F.E Pipe Fitting & Butt Weld Pipe Fitting of Stainless Steel & Carbon Steel

MFG UNIT: 16/A, Panchal Udhyog Nagar, Opp Old Syndicate bank, Ghoddev Phatak Road, Bhayander (E) Thane - 401105

## RANGE OF PRODUCTS

MANUFACTURES & EXPORTERS AS PER NATIONAL / INTERNATIONAL CODES & STANDARDS

L. R. BENDS, BUTTWELD SEAMLESS & WELDED PIPE FITTINGS FORGED SW FITTINGS & FLANGES		
Products	Materials	
LONG RADIUS BENDS	CARBON STEEL	STAINLESS STEEL
180 DEGREE U BEND	CARBON STEEL	STAINLESS STEEL
ELBOW L.R. / S.R.	CARBON STEEL	STAINLESS STEEL
CAPS		
REDUCERS / ECC & CON	CARBON STEEL	STAINLESS STEEL
STUBENDS, COLLARS		

## LONG RADIUS PIGGABLE BENDS

Seamless & Welded long radius piggable bends in 2D, 5D, 8D up to 22D, in Deg. of 45°, 90°, 180°, 360° size up to 32"NB with tangents length as per requirement. For L.R. Bends dimension tolerance, flattening on any point max. 1.7%, ovality within 1% of the diameter of pipe, Deg. +/- 1.5, thinning max.5% of W.T., No flaring, wrinkle free bends, dummy pig pass test done with 96% ID of bend and 'J', 'S', 'U' special bends.



# MUSKAN FORGE INDUSTRIES

All Types of simless Pipes Manufacturer of Flanges & P.T.F.E Pipe Fitting & Butt Weld Pipe Fitting of Stainless Steel & Carbon Steel

MFG UNIT: 16/A, Panchal Udhyog Nagar, Opp Old Syndicate bank, Ghoddev Phatak Road, Bhayander (E) Thane - 401105

## LONG RADIUS PIGGABLE BENDS

<b>MANUFACTURES &amp; EXPORTERS AS PER NATIONAL / INTERNATIONAL CODES &amp; STANDARDS</b>	
<b>PRODUCT, BENDING &amp; PROCEDURE</b>	
<b>L. R. PIGGABLE BENDS – ‘J’, ‘S’, ‘U’ &amp; SPECIAL BENDS WITH TANGENT LENGTH SEAMLESS &amp; WELDED COLD BENDING SIZE : 25 MM to 700 MM NB – THICKNESS : 3 MM to 30 MM (SCH.5 to SCH 160) RADIUS R=2D, 3D, 5D, 6D, 10D up to 22D Angle – 90°, 45°, 22.5°, 180° &amp; 360° degree</b>	
<b>TOLERANCE OF BEND</b>	
<b>FLATTENING ON ANY POINT MAX. 1.7% - OVALITY WITHIN 1% OF THE DIA. OF PIPE ANGLE +/- 1.5 DEG. - THINNING MAX. 10% OF W.T. OF PIPE NO FLARING, WRINKLE FREE BENDS DUMMY PIG PASS TEST DONE – WITH 96% ID OF BEND</b>	
<b>MATERIAL OF CONSTRUCTION OF BEND</b>	
<b>1) STAINLESS STEEL 2) CARBON STEEL</b>	
<b>FINAL INSPECTION &amp; TESTING</b>	
<b>CHEMICAL TEST  PHYSICAL TEST / MACRO / MICRO</b>	<b>Visual Inspection  Dimensional Inspection  Inspection on Layout</b>



# MUSKAN FORGE INDUSTRIES

All Types of simlless Pipes Manufacturer of Flanges & P.T.F.E Pipe Fitting & Butt Weld Pipe Fitting of Stainless Steel & Carbon Steel

MFG UNIT: 16/A, Panchal Udhyog Nagar, Opp Old Syndicate bank, Ghoddev Phatak Road, Bhayander (E) Thane - 401105

## INSPECTION & TESTING FACILITIES

- 1) ANGLE PLATE
- 2) DYE PENATRANT TEST KIT
- 3) "D" METER
- 4) OUTSIDE CALIPERS
- 5) VERNIER CALIPERS
- 6) MEASURING TAPES
- 7) SCALE

## MATERIALS OF CONSTRUCTION, SPECIFICATION & CODE

Materials	Specification	Size (mm)	Schedule	Method	Dimension
Stainless Steel.	A403WP304L,316L,317L,321,347H,310, 904L, UNS, 410S	15 to 250	5s to XXS	Seamless	B16.9
		NB	5s TO 80s	Welded	B16.28
Carbon Steel.		40 to 800			
		NB			



# MUSKAN FORGE INDUSTRIES

All Types of seamless Pipes Manufacturer of Flanges & P.T.F.E Pipe Fitting & Butt Weld Pipe Fitting of Stainless Steel & Carbon Steel

MFG UNIT: 16/A, Panchal Udhyog Nagar, Opp Old Syndicate bank, Ghoddev Phatak Road, Bhayander (E) Thane - 401105

## LIST OF MACHINERY

- **Details of Machineries for Manufacturing of fittings**

- Press Machine of Capacity of 300 tones
- Lathe Machines: - 06 Nos.
- Bench Grinder: - 01 Nos.
- Hack saw Machine: - 01 Nos.
- Simple Drill Machine: - 01 Nos.
- Coal Fired Furnace: - 01 Nos.
- Welding Machines: - 02 Nos.
- Gas cutting Sets :- 03 Nos
- Shaft Grinding Machines: - 02 Nos.
- PD – 100 Grinders: - 06 Nos.

- **New Machines Which will Going to install in Next 3 to 4 months are as follows:**

- Press Machine of Capacity 225 tones
- Press Machine of Capacity 75 tones.

- **Dies Available for Manufacturing of the Fittings**

- Dies of Elbows from 1/2" NB to 6" NB
- Die for 180 deg Return Bend up to 4" NB
- Seamless Cap Die from 8" NB to 24" NB
- For Reducers Concentric & Eccentric Reducers up to 16" NB

- **Dies under Manufacturing**

- Reducer Dies from 18" NB to 24" NB



# MUSKAN FORGE INDUSTRIES

All Types of seamless Pipes Manufacturer of Flanges & P.T.F.E Pipe Fitting & Butt Weld Pipe Fitting of Stainless Steel & Carbon Steel

MFG UNIT: 16/A, Panchal Udhyog Nagar, Opp Old Syndicate bank, Ghoddev Phatak Road, Bhayander (E) Thane - 401105

## MANUFACTURING PROCEDURE FOR LONG RADIUS PIGGABLE BENDS

### STAINLESS STEEL& CARBON STEEL,

- ✓ SEAMLESS & WELDED LONG RADIUS PIGGABLE BENDS
- ✓ MFG. RANGE : - 2D, 5D, 8D UPTO 22D, 45°, 90°, 180°, 360°, SIZE UPTO 24" NB

**DIMENSION TOLERANCES:-** FLATTENING ON ANY POINT MAX 1.7%, DEG.+/-1.5° OVALITY WITH IN 1.5% OF THE DIA. OF PIPE, THINNING MAX. 10% OF W.T., WRINKLE FREE BENDS. DUMMY PIG – PASS TEST SHALL BE DONE UPTO 96% ID OF BEND

- A. Technically clear Purchase Order.
- B. Manufacturing Codes / Standards as per Client Requirement / Approved Drawing / Approved QAP.
- C. Technical data like Material specification & Dimension, NDT requirement & it's Spec.
- D. Order the Raw Material as per requirement.
- E. Verification of purchased materials as per Purchase Order and spec.
- F. Co-relation of Heat No of Material with the Mill test Certificate.
- G. Co-relation of MTC as per spec.
- H. For all accepted materials Visual and dimensional checks are carried out.
- I. If original MTC is not received / not available, check testing is carried out.
- J. Marking on pipes are done, as per cutting length make sure the individual pieces bears the allotted Lot No.
- K. The pipes are filled with sand, lead or Gum based Rosin.
- L. After filling, the pipes are taken for further Hot / Cold forming process.
- M. Stage wise inspection is carried out on processing level like Flattening, ovality, thinning, Wrinkle & Angle.
- N. Final inspection is carried out on bending machine, before taken out for final processing.
- O. Visual and Dimension check are carried out during production for Flattening radius Diameter / Ovality, Height Bevel end angle, Min. & Max. Thickness is recorded. NDT is carried out as per Approved QAP / DRG.
- P. Heat Treatment : - For S.S. solution annealing, A.S. annealing, C.S. normalizing Test coupon are send for check testing as per specification / Approved QAP / DRG./ Client requirement.
- Q. C.S. Bends are wire brushed and rust preventives are applied before dispatch.

## DIMENSIONS & DIAGRAMS

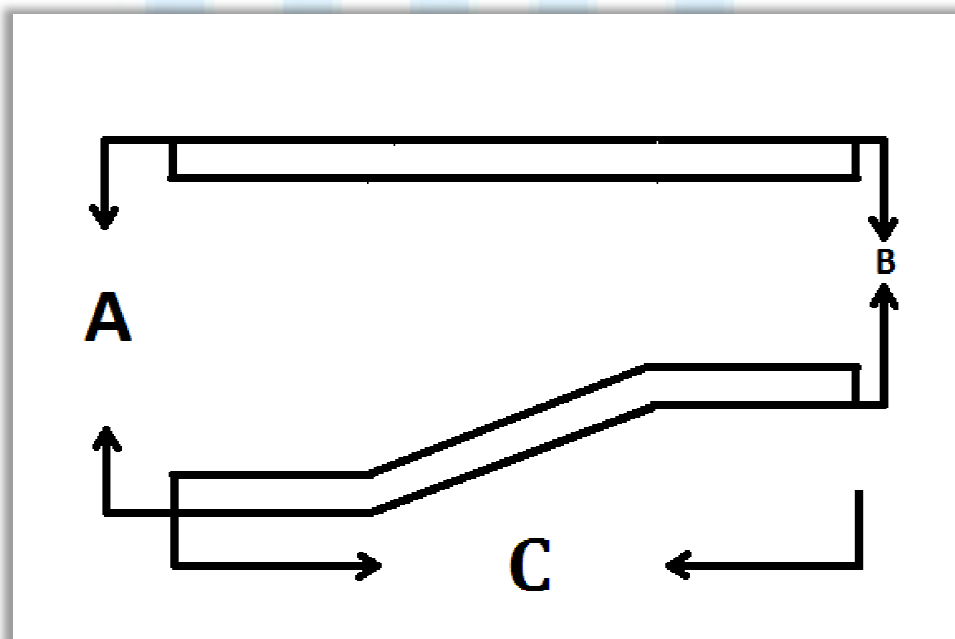
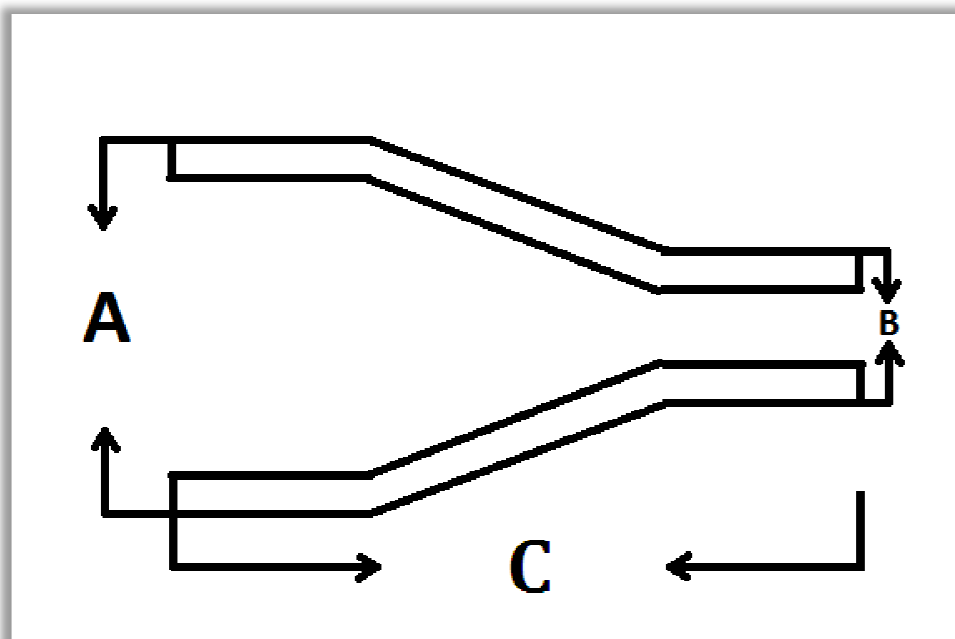





# MUSKAN FORGE INDUSTRIES

All Types of simlless Pipes Manufacturer of Flanges & P.T.F.E Pipe Fitting & Butt Weld Pipe Fitting of Stainless Steel & Carbon Steel

MFG UNIT: 16/A, Panchal Udhyog Nagar, Opp Old Syndicate bank, Ghoddev Phatak Road, Bhayander (E) Thane - 401105

## DIMENSIONS OF REDUCERS CONCENTRIC & ECCENTRIC

Sr. No.	CONCENTRIC & ECCENTRIC REDUCER	SIZE	LENGTH
1.)	25 NB	15NB	108
		20NB	108
2)	40 NB	20NB	108
		25NB	108
3)	50 NB	25NB	120
		40NB	120
4)	80 NB	25NB	145
		40NB	145
		50NB	145
		65NB	145
5)	100 NB	25NB	170
		40NB	170
		50NB	170
		65NB	170
		80NB	170
6)	150 NB	25NB	221
		40NB	221
		50NB	221
		65NB	221
		80NB	221
		100NB	221
7)	200 NB	40NB	272
		50NB	272
		65NB	272
		80NB	272
		100NB	272
		150NB	272
8)	250 NB	80NB	297
		100NB	297
		150NB	297
		200NB	297

Regd Add: - B-1/409, Jyoti Park, Opp. Indralok Complex Phase-I, New Golden Nest Road, Bhayander (East) Thane-401105

Email: - [muskanforgeind@yahoo.in](mailto:muskanforgeind@yahoo.in)

Tell: - +9122 28165151

## DIMENSIONS & DIAGRAM of BEND

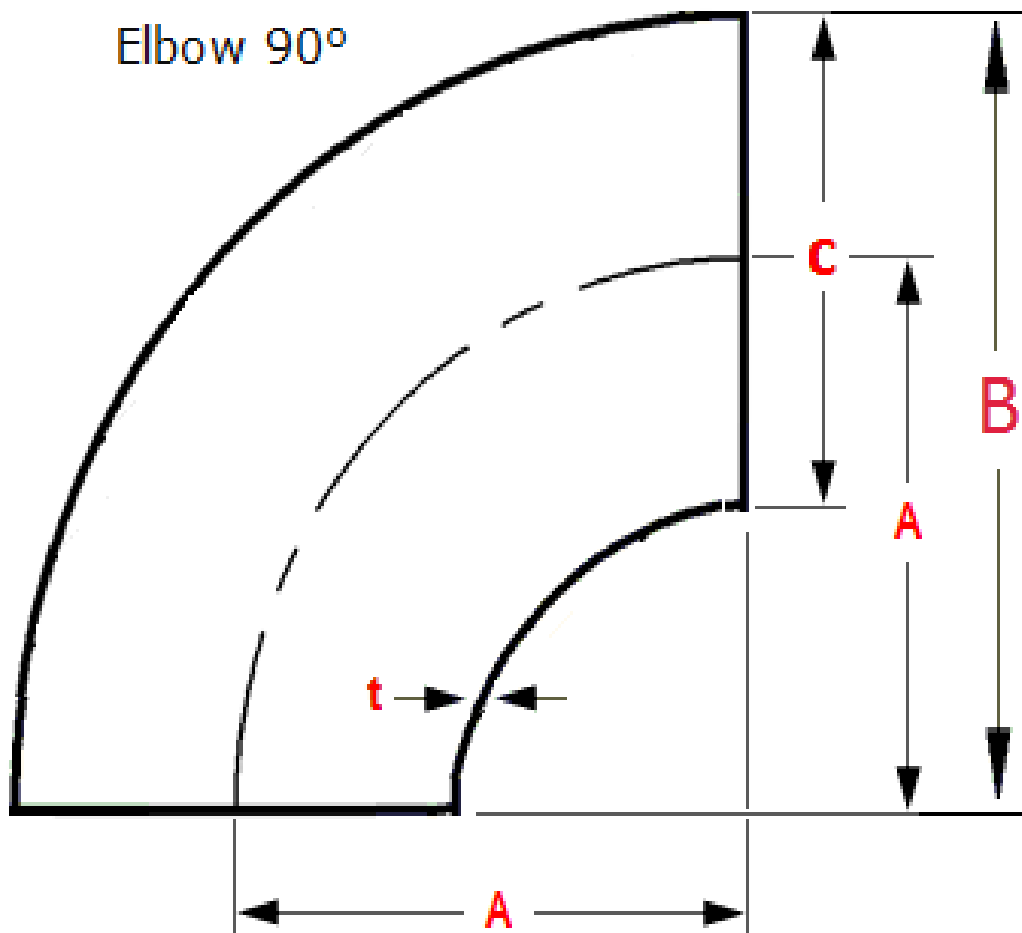

NOTE – Tolerance will be  $0.5\text{mm} \pm$  in OD and ID.

Tolerance will be  $2\text{mm} \pm$  in height



# MUSKAN FORGE INDUSTRIES

All Types of simlless Pipes Manufacturer of Flanges & P.T.F.E Pipe Fitting & Butt Weld Pipe Fitting of Stainless Steel & Carbon Steel

MFG UNIT: 16/A, Panchal Udhyog Nagar, Opp Old Syndicate bank, Ghoddev Phatak Road, Bhayander (E) Thane - 401105

## DIMENSIONS OF BEND

Sr. No	SIZE MM	SIZE INCH	A Centre Height	B Total Height	C OD Size
1.)	15 NB	½"	65mm	75.5mm	21.3mm
2.)	20NB	¾"	75mm	88mm	26.5mm
3.)	25NB	1"	89mm	105mm	33.5mm
4.)	40NB	1 ½"	102mm	126mm	48.3mm
5.)	50NB	2"	114mm	141mm	60.3mm
6.)	80NB	3"	140mm	185mm	89mm
7.)	100NB	4"	165mm	220mm	114.5mm
8.)	150NB	6"	203mm	287mm	168.3mm
9.)	200NB	8"	229mm	338mm	219mm
10.)	250NB	10"	279mm	415mm	273mm